

# RULMENȚI



Figura 4.1



Figura 4.2

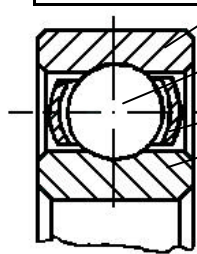

Figura 4.3

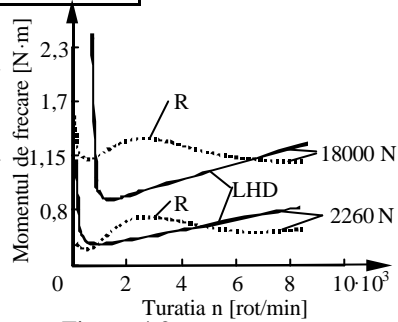

Figura 4.4

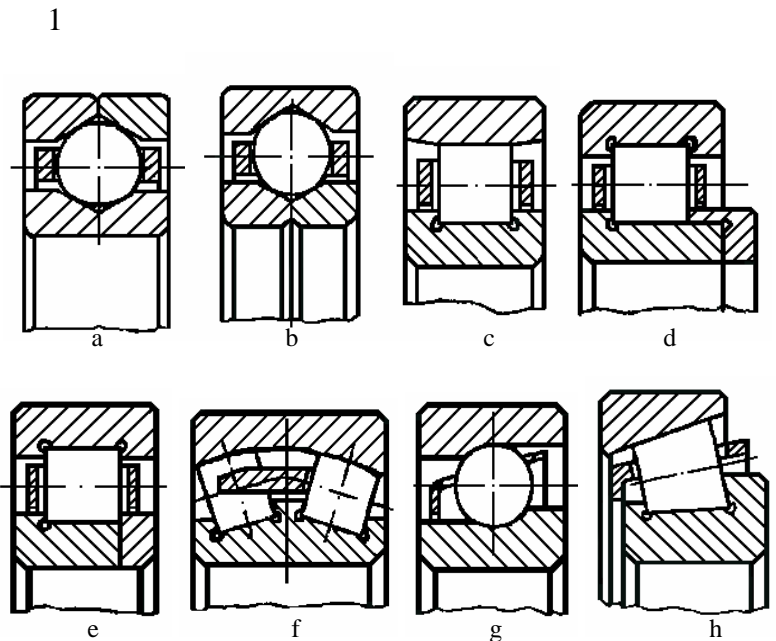

Figura 4.5

$$\delta = C \cdot F^n \quad (4.1)$$

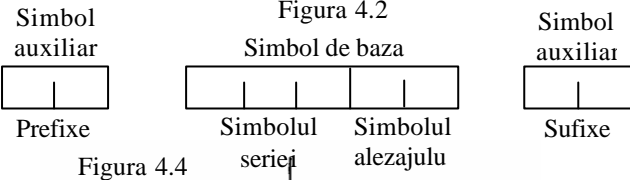
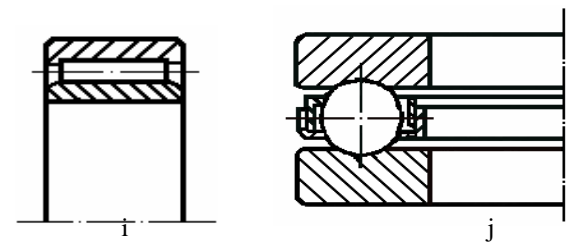
$$\begin{cases} \delta_0 = C \cdot F_0^{2/3}; \\ \delta_1 = C \cdot F_1^{2/3}; \\ \vdots \\ \delta_n = C \cdot F_n^{2/3} \end{cases} \quad (4.2)$$

$$\frac{\delta_1}{\delta_0} = \left(\frac{F_1}{F_0}\right)^{2/3}; \quad \frac{\delta_2}{\delta_0} = \left(\frac{F_2}{F_0}\right)^{2/3} \quad (4.3)$$

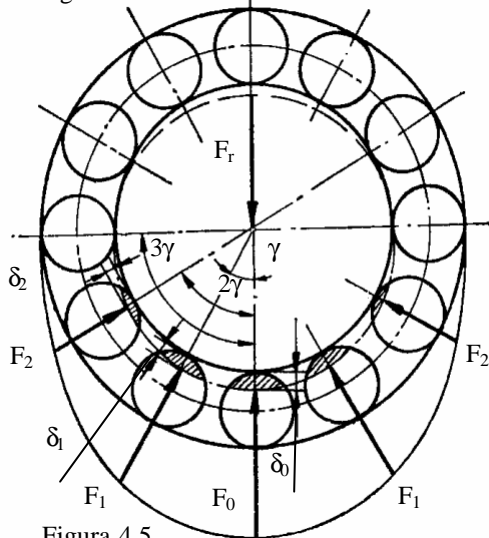
$$F_1 \cdot \cos \gamma = F_0 \cdot (\cos \gamma)^{5/2}; \quad F_2 \cdot \cos 2\gamma = F_0 \cdot (\cos 2\gamma)^{5/2} \dots F_n \cdot \cos n\gamma = F_0 \cdot (\cos n\gamma)^{5/2} \quad (4.4)$$

$$F_r = F_0 + 2 \cdot F_1 \cdot \cos \gamma + 2 \cdot F_2 \cdot \cos 2\gamma + \dots + 2 \cdot F_n \cdot \cos n\gamma \quad (4.5)$$

$$F_r = F_0 \left[ 1 + 2 \cdot \sum_{i=1}^n (\cos i\gamma)^{5/2} \right] \quad (4.6)$$

$$F_0 = \frac{F_r}{1 + 2 \cdot \sum_{i=1}^n (\cos i\gamma)^{5/2}} = \frac{K_b \cdot F_r}{z} \quad (4.7)$$

$$F_0 = \frac{5 \cdot F_r}{z} \quad (4.8)$$

$$F'_0 = \frac{5,2 \cdot F_r}{z} \quad (4.9)$$

$$Q = \frac{F_a \pm F'_a}{z \cdot \sin \beta} \quad (4.10)$$

$$L = \left(\frac{C}{P}\right)^p \quad (4.11)$$



Figura 4.6

$$I_{uh} = 3,5 \cdot 10^{-10} \frac{A \cdot K}{M}$$

$$R_{int} = \frac{R_1 \cdot R_2}{R_1 + R_2}; \quad R_{ext} = \frac{R_1(R_2 + 2R_1)}{R_1 + R_2}$$

$$\omega_1 = \frac{R_2 \cdot (R_2 + 2 \cdot R_1)}{2 \cdot R_1 \cdot (R_1 + R_2)} \cdot \omega_2; \quad \omega_2 = \frac{n}{30} \text{ rad/sec}$$

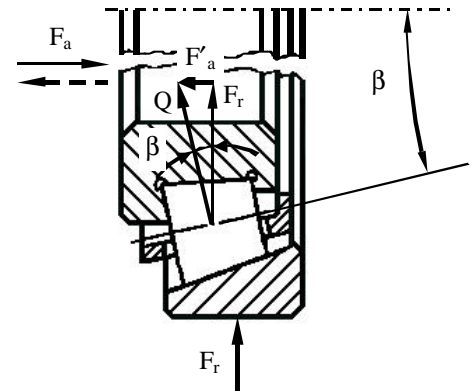
$$\chi_h = K \cdot d_m (\eta_0 \cdot \alpha \cdot n)^{0,73} \cdot C_0^{-0,09}$$

$$\eta_0 = \alpha \cdot C_0^{0,123} \left( \frac{\chi_{h \text{ optim}}}{K \cdot d_m} \right)^{1,37}$$

$$\sigma_{Hmax} = 0,418 \cdot \sqrt{\frac{F_r \cdot E_r}{1} \cdot \left( \frac{1}{R_1} \pm \frac{1}{R_{2,3}} \right)}$$

$$M_t = M_F + M_L$$

$$M_F = f_1 \cdot F_r \cdot d_m$$

$$M_L = 10^3 \cdot f_0 \cdot (v \cdot n)^{2/3} \cdot d_m^3 \text{ [N}\cdot\text{m]} \text{ pentru } v \cdot n > 2 \cdot 10^{-3};$$

$$M_L = 24,1 \cdot f_0 \cdot d_m \text{ [N}\cdot\text{m]} \text{ pentru } v \cdot n \leq 2 \cdot 10^{-4}.$$

$$L_{10} = \left( \frac{C}{P} \right)^p; \quad L_h = \frac{10^6}{60 \cdot n} \left( \frac{C}{P} \right)^p$$

$$h_{uz} = v_{uz} \cdot t_h$$

$$v_{uz} = K_{rm} \cdot \epsilon_a^{2/3} \cdot R_a^{1/5} \cdot \sigma_a^{2,5} \cdot \omega$$

$$R_r = R_{uz} \cdot R_{abr}$$

$$n_{lim} = \frac{K_n}{D - 10} \text{ [rot/min]}$$

$$n_{lim} = \frac{3 \cdot K_n}{D + 30} \text{ [rot/min]}$$

$$n_{lim}^* = n_{lim} \cdot f_{n1} \cdot f_{n2} \cdot f_{n3} \cdot f_{n4}$$

$$L_h = \frac{10^6 \cdot L}{60 \cdot n}$$

$$L = \left( \frac{C}{P} \right)^p$$

(4.12)

(4.13)

(4.14)

(4.15)

(4.16)



Figura 4.7

(4.17)

(4.18)

(4.19)

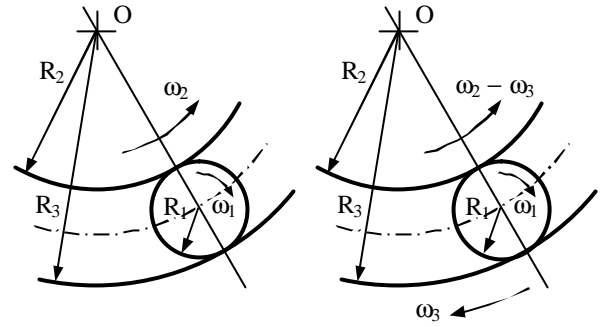
(4.20)

(4.21)

(4.22)

(4.23)

(4.24)

(4.25)

(4.26)

(4.27)

(4.28)

(4.29)



Figura 4.9



Figura 4.10

$$\operatorname{tg} \beta_1 = e \tag{4.30}$$

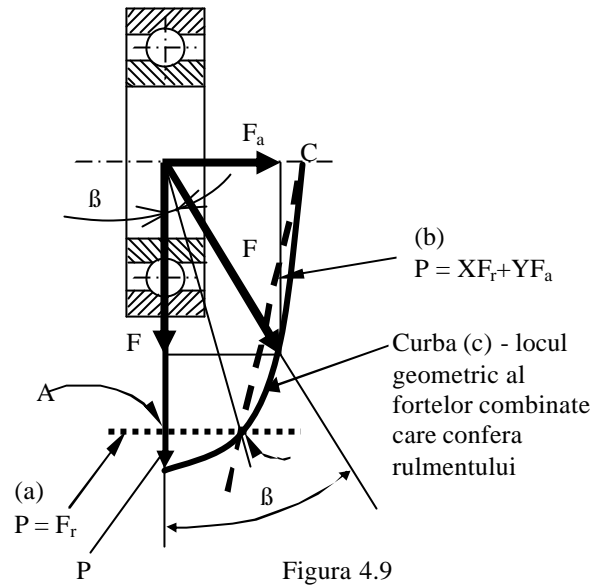
$$P = F_r \tag{4.31}$$

$$P = V \cdot X \cdot F_r + Y \cdot F_a \tag{4.32}$$

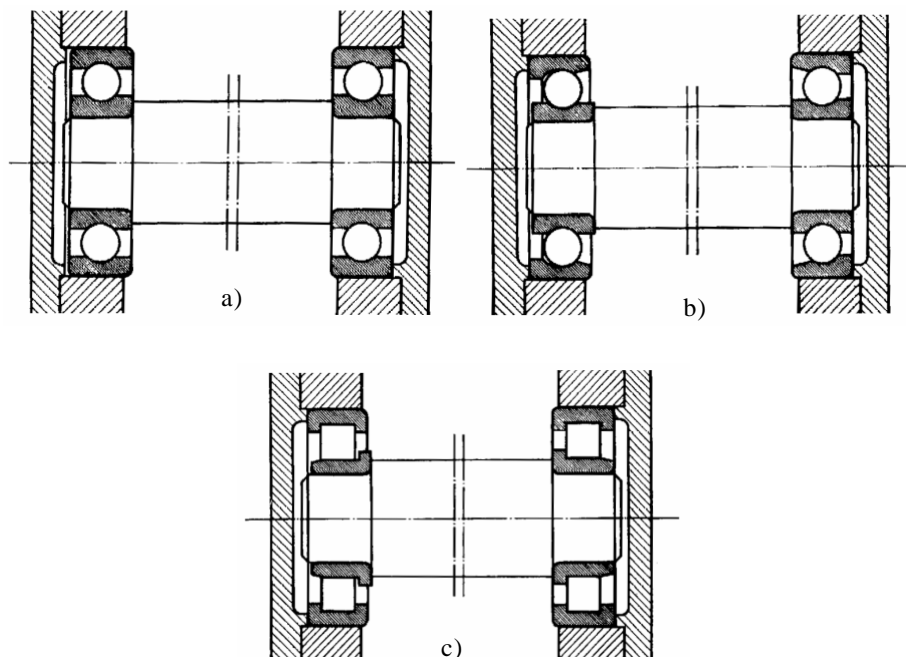

Figura 4.11



Figura 4.12

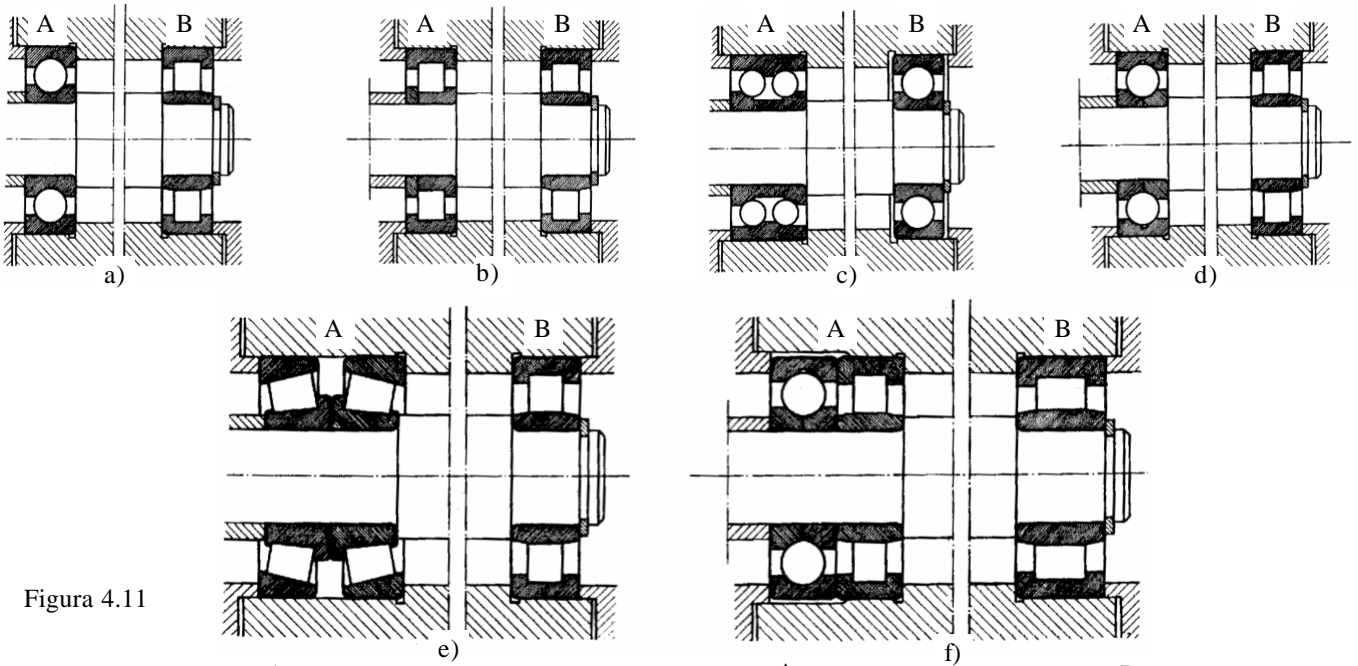

Figura 4.13

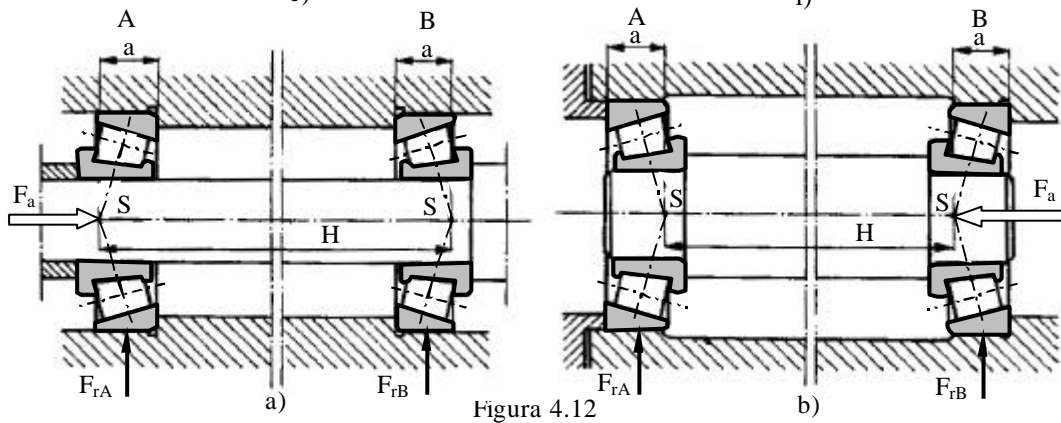

Figura 4.14

Tabelul 4.1

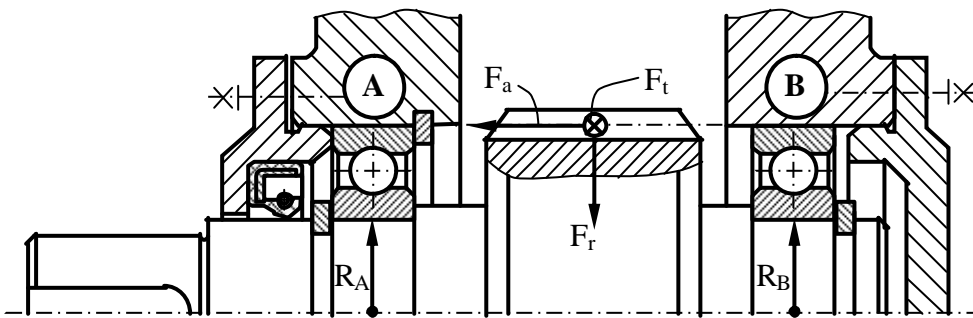
Simbolul rulmentului	6007	6207	6307	6407)
Diametrul alezajului d (mm)	35	35	35	35
Diametrul exterior al rulmentului D (mm)	62	72	80	100
Latimea rulmentului B (mm)	14	17	21	25
Capacitatea de încărcare statica $C_0$ [kN]	8,65	14,0	18,3	31,9
Capacitatea dinamica de baza C [kN]	12,5	20,0	26,0	43,6
Factorul X	0,6	0,6	0,6	0,6
Factorul Y	0,5	0,5	0,5	0,5
Factorul V	V = 1, daca se roteste inelul interior V = 1,2, daca se roteste inelul exterior			
e	(se determina prin interpolare din catalogul de rulmenti, în functie de raportul $F_a / C_0$ )	(se determina prin interpolare din catalogul de rulmenti, în functie de raportul $F_a / C_0$ )	(se determina prin interpolare din catalogul de rulmenti, în functie de raportul $F_a / C_0$ )	(se determina prin interpolare din catalogul de rulmenti, în functie de raportul $F_a / C_0$ )

Tabelul 4.2

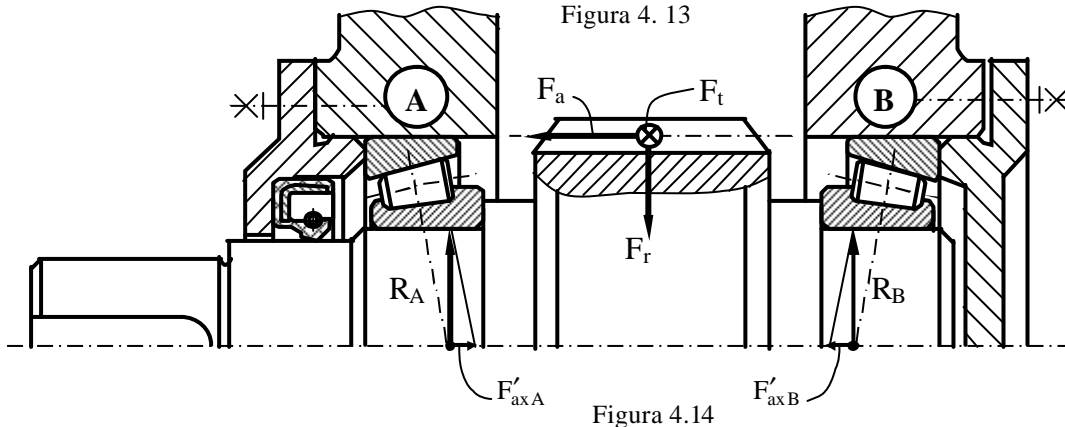
Simbolul rulmentului	6007	6207	6307)	6407
<i>Rulmentul liber</i> Încărcarea echivalenta, $P_A$	$P_A = R_A$	$P_A = R_A$	$P_A = R_A$	$P_A = R_A$
<i>Rulmentul conducator</i> Încărcarea echivalenta, $P_B$	$P_B = R_B$ , daca $F_a/R_B = e$ sau $P_B = V \cdot X \cdot R_B + Y \cdot F_a$ , daca $F_a/R_B > e$	$P_B = R_B$ , daca $F_a/R_B = e$ sau $P_B = V \cdot X \cdot R_B + Y \cdot F_a$ , daca $F_a/R_B > e$	$P_B = R_B$ , daca $F_a/R_B = e$ sau $P_B = V \cdot X \cdot R_B + Y \cdot F_a$ , daca $F_a/R_B > e$	$P_B = R_B$ , daca $F_a/R_B = e$ sau $P_B = V \cdot X \cdot R_B + Y \cdot F_a$ , daca $F_a/R_B > e$
Încărcarea echivalenta maxima $P_{max}$	Se înscrie valoarea cea mai mare dintre $P_A$ si $P_B$ , adica $P_{max}$	Se înscrie valoarea cea mai mare dintre $P_A$ si $P_B$ , adica $P_{max}$	Se înscrie valoarea cea mai mare dintre $P_A$ si $P_B$ , adica $P_{max}$	Se înscrie valoarea cea mai mare dintre $P_A$ si $P_B$ , adica $P_{max}$
Durabilitatea în milioane de rotatii, L	$L = \left( \frac{C}{P_{max}} \right)^3$	$L = \left( \frac{C}{P_{max}} \right)^3$	$L = \left( \frac{C}{P_{max}} \right)^3$	$L = \left( \frac{C}{P_{max}} \right)^3$
Durabilitatea în ore de functionare, $L_h$	$L_h = \frac{L \cdot 10^6}{60 \cdot n}$	$L_h = \frac{L \cdot 10^6}{60 \cdot n}$	$L_h = \frac{L \cdot 10^6}{60 \cdot n}$	$L_h = \frac{L \cdot 10^6}{60 \cdot n}$

$$L_h \geq L_{h \text{ admisibil}}$$

(4.33)



Figura 4.15

$$F'_{axA,B} = 0,5 \cdot \frac{R_{A,B}}{Y_{A,B}}$$

(4.34)

Tabelul 4.3

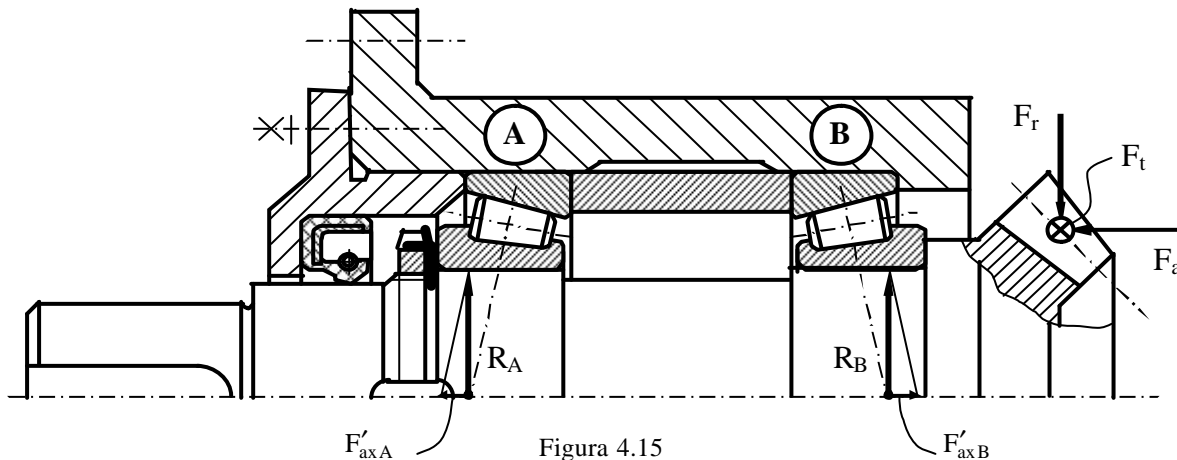
Simbolul rulmentului	32009 X	33109	33209	30309 A
Diametrul alezajului, d (mm)	45	45	45	45
Diametrul exterior al rulmentului, D (mm)	75	80	85	100
Latimea rulmentului, B (mm)	20	26	32	25
Capacitatea dinamicade baza, C [N]	44	71	91,5	
Factorul X	0,67	0,67	0,67	0,67
Factorul Y	1,5	1,6	1,5	1,7
Factorul V	V = 1 daca se roteste inelul interior			
	V = 1,2 daca se roteste inelul exterior			
e	0,4	0,37	0,4	0,35

$$L_h \geq L_{h \text{ admisibil}} \quad (4.35)$$

Tabelul 4.4

Conditii de încarcare	Forța axială totală de calcul	
	Rulmentul A	Rulmentul B
$\frac{R_A}{Y_A} \leq \frac{R_B}{Y_B}$	$F_{axA}^{total} = F_a + 0,5 \cdot \frac{R_B}{Y_B}$	—
$\frac{R_A}{Y_A} > \frac{R_B}{Y_B}$ $F_a > 0,5 \cdot \left( \frac{R_A}{Y_A} - \frac{R_B}{Y_B} \right)$	$F_{axA}^{total} = F_a + 0,5 \cdot \frac{R_B}{Y_B}$	—
$\frac{R_A}{Y_A} > \frac{R_B}{Y_B}$ $F_a \geq 0,5 \cdot \left( \frac{R_A}{Y_A} - \frac{R_B}{Y_B} \right)$	—	$F_{axB}^{total} = F_a - 0,5 \cdot \frac{R_B}{Y_B}$

Tabelul 4.5

Simbolul rulmentului	32009 X (exemplu)	33109 (exemplu)	33209 (exemplu)	30309 A (exemplu)
<b>Rulmentul din A</b> <b>Încarcarea echivalenta P<sub>A</sub></b>	$P_A = R_A,$ daca $F_{axA}^{total} / R_A > e$ sau $P_A = V \cdot X \cdot R_A + Y \cdot F_{axA}^{total}$ daca $F_{axA}^{total} / R_A > e$	$P_A = R_A,$ daca $F_{axA}^{total} / R_A > e$ sau $P_A = V \cdot X \cdot R_A + Y \cdot F_{axA}^{total}$ daca $F_{axA}^{total} / R_A > e$	$P_A = R_A,$ daca $F_{axA}^{total} / R_A > e$ sau $P_A = V \cdot X \cdot R_A + Y \cdot F_{axA}^{total}$ daca $F_{axA}^{total} / R_A > e$	$P_A = R_A,$ daca $F_{axA}^{total} / R_A > e$ sau $P_A = V \cdot X \cdot R_A + Y \cdot F_{axA}^{total}$ daca $F_{axA}^{total} / R_A > e$
<b>Rulmentul din B</b> <b>Încarcarea echivalenta P<sub>B</sub></b>	$P_B = R_B,$ daca $F_{axB}^{total} / R_B = e$ sau $P_B = V \cdot X \cdot R_B + Y \cdot F_{axB}^{total}$ daca $F_{axB}^{total} / R_B > e$	$P_B = R_B,$ daca $F_{axB}^{total} / R_B = e$ sau $P_B = V \cdot X \cdot R_B + Y \cdot F_{axB}^{total}$ daca $F_{axB}^{total} / R_B > e$	$P_B = R_B,$ daca $F_{axB}^{total} / R_B = e$ sau $P_B = V \cdot X \cdot R_B + Y \cdot F_{axB}^{total}$ daca $F_{axB}^{total} / R_B > e$	$P_B = R_B,$ daca $F_{axB}^{total} / R_B = e$ sau $P_B = V \cdot X \cdot R_B + Y \cdot F_{axB}^{total}$ daca $F_{axB}^{total} / R_B > e$
<b>Încarcarea echivalenta maxima, P<sub>max</sub></b>	Se înscrie valoarea cea mai mare dintre P <sub>A</sub> și P <sub>B</sub> , adica P <sub>max</sub>	Se înscrie valoarea cea mai mare dintre P <sub>A</sub> și P <sub>B</sub> , adica P <sub>max</sub>	Se înscrie valoarea cea mai mare dintre P <sub>A</sub> și P <sub>B</sub> , adica P <sub>max</sub>	Se înscrie valoarea cea mai mare dintre P <sub>A</sub> și P <sub>B</sub> , adica P <sub>max</sub>
<b>Durabilitatea în milioane de rotatii, L</b>	$L = \left( \frac{C}{P_{max}} \right)^3$	$L = \left( \frac{C}{P_{max}} \right)^3$	$L = \left( \frac{C}{P_{max}} \right)^3$	$L = \left( \frac{C}{P_{max}} \right)^3$
<b>Durabilitatea în ore de functionare, L<sub>h</sub></b>	$L_h = \frac{L \cdot 10^6}{60 \cdot n}$	$L_h = \frac{L \cdot 10^6}{60 \cdot n}$	$L_h = \frac{L \cdot 10^6}{60 \cdot n}$	$L_h = \frac{L \cdot 10^6}{60 \cdot n}$